



M-Line

M4.45

● ● ● ● 30.9 kW / 42 HP



Supplied as standard with instrument panel type MPA22KBS2 (see page 128), four flexible engine mounts type KSTEUN75V (see page 54) and a pre-installed oil sump pump.

TECHNICAL SPECIFICATIONS

Engine model	M4.45
Max. output at flywheel (ISO 8665)	30.9 kW (42 hp)
Max. output at propeller shaft (ISO 8665)	30 kW (40.8 hp)
Maximum rpm	3000
Max. torque	106.4 Nm / 1750 rpm
Bore x stroke	78 mm x 92 mm
Displacement	1758 cm ³
Number of cylinders	4 in line
Combustion system	indirect injection
Compression ratio	22:1
Firing order	1-3-4-2
Intake	naturally aspirated
Electrical system	12 VDC - 110 Amps.
Cooling system (standard)	indirect cooling (keel cooling optional)
Gearbox, standard	TMC60 (2 / 2.5 / 2.94:1)
Gearbox options	ZF12M 2.14 / 2.63:1 TMC60A 2 / 2.5:1
Saildrive	SP60 2.15 / 2.38:1 SD10 2.23 / 2.49:1
Dry weight (incl. std. gearbox)	199 kg
Fuel consumption at 2500 rpm	252 g / kW.h (185 g / hp.h)
Max. backwards installation angle	15°
Max. lateral inclination angle;	
Continuously	25°
5 minutes max.	30°
Suction height of fuel lift pump	1.5 m
Calorifier connection kit	optional
Instrument panel (standard)	MPA22KBS2
Warning lights and audible alarm	oil pressure, temperature and (coolant exhaust), charging current
Control light for	pre-heating/glow plugs
Electric circuit protection	fuse 20 Amps.
Certifications	EU-RCD II, BSO II, SOLAS

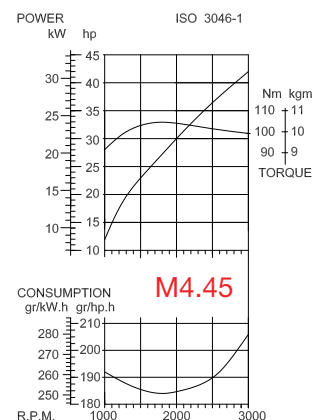
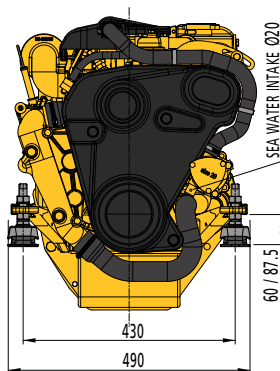
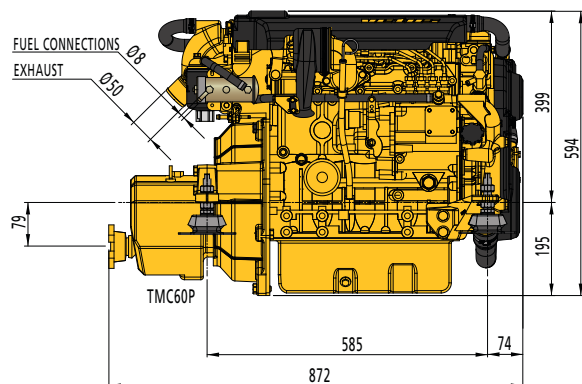

Certified within 5%